

0. ABSTRACT

In this work we present the design of a portable radio-frequency diathermy (RFD) prototype and its initial medical validation. The electronic circuit consists of a voltage-controlled oscillator, a low-frequency oscillator and a voltage amplifier powered by a rechargeable battery. Circuit was designed to develop a pulsed output of 120 V at a frequency ranging from 500 KHz to 1 MHz. The RFD circuit was implemented with commercially available components and assembled on a printed circuit board (PCB). The complete product, including flexible electrodes, was assembled on a 6 cm x 9 cm x 3 cm cabinet. Experimental results show that the output can reach a pulsed voltage of 84 Vpp and a current consumption of 23 mA during 48 hours of continuous operation, which fulfills the autonomy requirement of portable devices for low power RFD applications. A comparative study according to physical rehabilitation protocol was carried out on a universe of 20 patients with lumbago disease with continuous RFD treatment using our prototype versus a traditional RFD treatment. Preliminary results show that muscle healing was more effective in patients with continuous RFD treatment, validating this prototype for therapeutic applications.

1. INTRODUCTION

Heat has been used for many years for healing injured muscle tissue. The two most recognized techniques are ultrasound and diathermy. Diathermy uses alternating currents that oscillate at frequencies in the nonionizing RF band of the spectrum, heating localized regions of the body at depths of about 3 cm, without overheating the overlying structures of skin and **subcutaneous** tissues [1], [2]. The heating results from both ionic conduction and vibration of the dipole molecules of water and proteins of tissue [3].

For treating some muscle illness, such as reducing pain and inflammation, decreasing joint stiffness, relieving muscle spasms by increased local blood flow, and treating other rheumatic diseases, diathermy devices operate at frequencies in the range of 100 kHz – 4 MHz [4], [5].

RFD devices are typically bulky and require AC power supply. When an RFD treatment is prescribed, generally patients must go to the specialist's office for therapy and progress evaluation. Typical RFD treatments include the application to the patient of a high frequency signal for about 20 minutes in weekly sessions during at least one month, yielding long time treatments. The aim of this work is to contribute to the improvement of RFD treatments by means of a low-cost portable RFD prototype for continuous-mode RFD application. We describe in general terms the design of a small-size and portable RFD prototype to generate a voltage of amplitude in the range of 50 V to 120 V and frequency sweep in the range of 500 kHz to 1 MHz, with the capability to repeat this sweep every second. As an initial validation of this prototype, a study using a physical rehabilitation protocol was performed on a universe of 20 patients with lumbago disease. Preliminary results show that the healing of the muscle with continuous mode RFD treatment was more effective and the time to relieve pain was drastically reduced.

2. PROTOTYPE DESIGN

In this work we describe in general terms the design of the proposed RFD prototype (Fig. 1). The low-frequency oscillator (LFO) and the voltage-controlled oscillator (VCO) blocks are implemented with an 8-bit PIC10F200-I/P microcontroller from Microchip Co. The internal timer of this microcontroller is used to generate the time references needed to produce a signal with an amplitude in the range from 0 to 5 V and a frequency sweep from 500 kHz to 1 MHz.

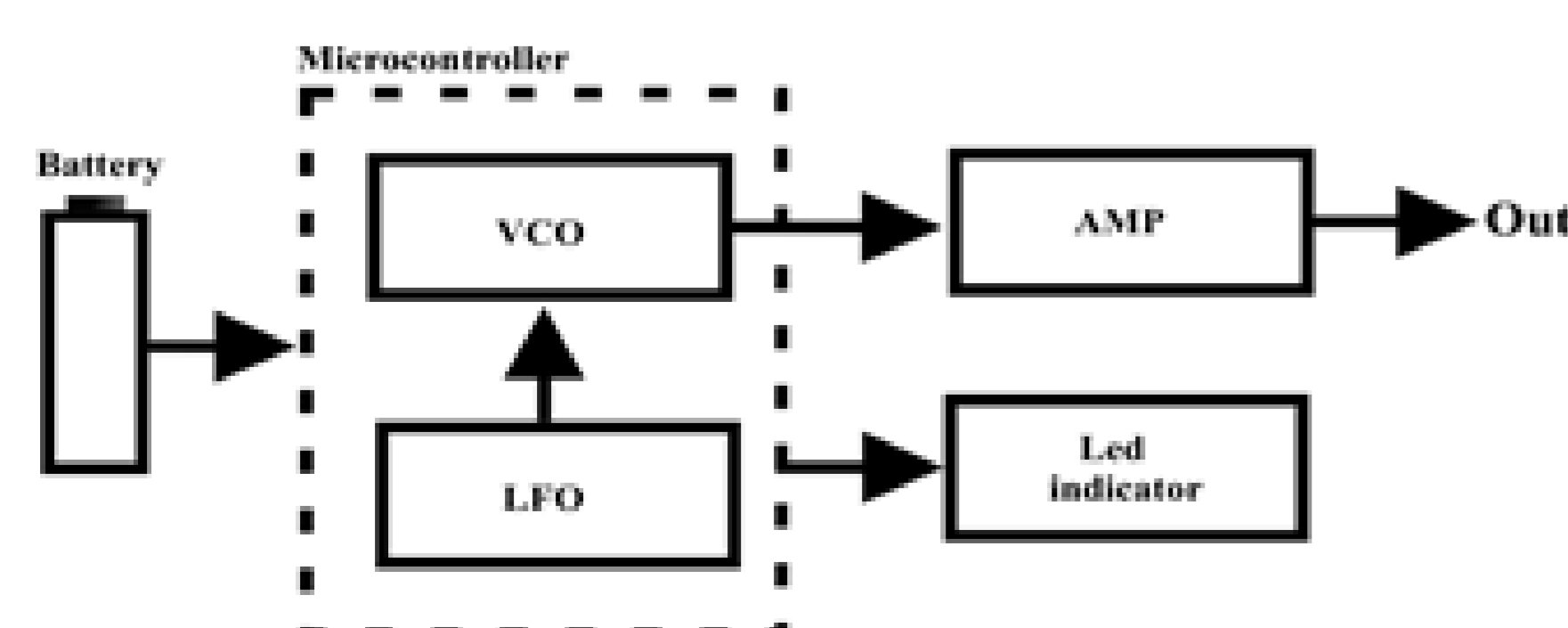

Fig. 1. Block diagram proposed for the radio-frequency diathermy (RFD) prototype.

The voltage amplifier was designed for a voltage gain of 24 V/V using a commercial power MOSFET with a passive inductor load of 1 mH capable to work with an $I_{max} = 150$ mA [6].

The nMOS transistor was selected in terms of the required transconductance g_m and drain current I_D . g_m was derived from the voltage gain relationship of a common-source amplifier without source-resistance degeneration, and we obtain a g_m in the range of 3.82 – 5.46 mA/V. Then, considering the relationship,

$$g_m = 2 \frac{I_D}{V_{eff}} \quad (1)$$

where $V_{eff} = V_{GS} - V_{Th}$ is the transistor overdrive voltage, we find the required minimum I_D of 5.73 mA. Thus, to ensure proper operation, we select a power MOSFET with much larger I_D than the previously calculated. The total current consumption of the entire circuit I_{bat} was experimentally verified on several patients under RFD treatment, finding an average value of $I_{bat} = 23$ mA. In order to fulfill the portability requirements, we use a rechargeable battery as power supply. This battery was chosen in terms of its operation time T_o (or battery life), given by

$$T_o = 0.7 \frac{C_{bat}}{I_{bat}} \quad (2)$$

where C_{bat} is the battery charge capacity. Considering at least 48 hours of continuous operation and a total current consumption $I_{bat} = 23$ mA, from (2) a $C_{bat} = 1,577$ mAh is needed. We selected a commercial battery with $C_{bat} = 2,000$ mAh and an output voltage of 5 VDC [7].

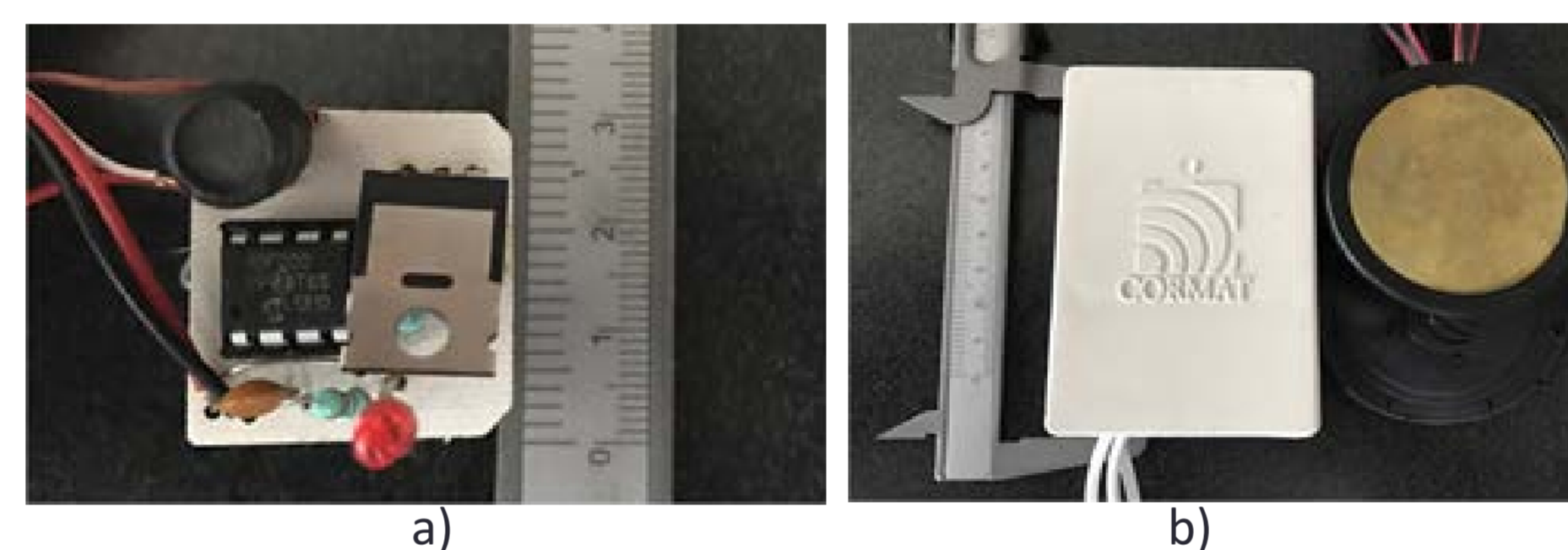

Fig. 2. Radio-frequency diathermy (RFD) circuit prototype: a) components on PCB; b) case and sensor.

3. VALIDATION AND DISCUSSION

The prototype was tested with a universe of 20 patients with recent lumbago (lower back pain) illness, following the physical rehabilitation protocol. Firstly, a clinical history was recorded up for each patient (information included: name, age, weight, height, number of children, occupation, marital status, hereditary medical history, and personal medical history). Secondly, patients were divided into two groups of similar pairs, for example, two patients with obesity, two elderly patients, or two female patients, etc. (see details in Table I). A group of 10 patients received conventional electrotherapy treatment (Group A), while the other 10 patients group received conventional electrotherapy plus continuous RFD treatment at home using the proposed prototype (Group B). The conventional electrotherapy treatment consisted of the application of 1 MHz of ultrasound at an intensity of 2.4 W/cm² during 10 minutes, followed by 10 minutes of electro-stimulation with a pulsed electrical current at an intensity of 40 mA. This treatment was applied with a commercial electrotherapy device of Cormat Co. [5], two times per week. After applying ultrasound and electro-stimulation treatments, patients perform flexion, extension, and rotation exercises in the affected part of body.

TABLE I: MEDICAL RECORD OF PATIENTS UNDER STUDY

No. Patient / Group	Age (years)	Sex	History of diseases	Personal background
1/A	37	F	HT+DIA+OW	Scoliosis
2/A	84	M	HT+CA	DIA
3/A	31	M	HT+DIA	Smoker
4/A	54	F	HT	---
5/A	49	F	DIA+CA	Hypotension
6/A	17	M	HT+DIA+VI	Surgery
7/A	32	F	CA+DIA	Ovarium tumor
8/A	51	M	HT+CA	OW
9/A	21	M	---	Fracture
10/A	19	M	DIA	---
1/B	62	F	HT+DIA	Surgery
2/B	70	F	HT	Gastritis
3/B	56	F	DIA	DIA
4/B	63	F	HT+DIA	Surgery
5/B	59	F	CA	Hypotension
6/B	22	F	CA+DIA	Gastritis
7/B	18	M	DIA+HT	---
8/B	23	M	DIA	Dysplasia
9/B	22	M	HT+DIA+CA	Amputation
10/B	23	M	---	Surgery

HT: hypertension; DIA: diabetes; OW: overweight; VINS: vein insufficiency

As previously mentioned, Group B received continuous RFD treatment at home; patients were provided in their first visit with our RFD prototype placed by the therapists on the injured area. After two days of continuous treatment, patients of Group B come back to the specialist's office. In each reviewing visit, the RFD device is removed so that the patients can do their exercises. At the end of the exercise session, the device is put in place once again. These same steps were repeated during 5 sessions in a row, which take approximately two and a half weeks. Every 2 sessions the relieving pain and lower-back flexibility of both Group A and Group B was measured with typical techniques used in physical rehabilitation, i.e., Shober goniometry [8], [9] and the visual analogue scale (VAS) [10].

After the fourth reviewing visit, the relieving pain and muscle flexibility results of Group A and Group B were compared to evaluate whether the continuous RFD treatment offers an advantage when used in this type of therapy with different kinds of patients. Fig. 3 shows the evolution of pain reduction and the recovery of lower-back elasticity in patients of Group A and Group B, respectively. It is clear from the figure that the relieving pain and increased elasticity was better for the Group B. In this figure we can observe a decrease of 80% of pain in patients who have used the RFD device continuously, as compared to 50% improvement in the patients who received traditional therapy. Regarding elasticity, a 22% of increased elasticity was estimated in the patients who have used the RFD device continuously, as compared to a 7% improvement in the patients who received traditional therapy. Although these results are still not concluding, in this study, it can be seen a more effective muscle healing by applying a continuous-mode RFD signal.

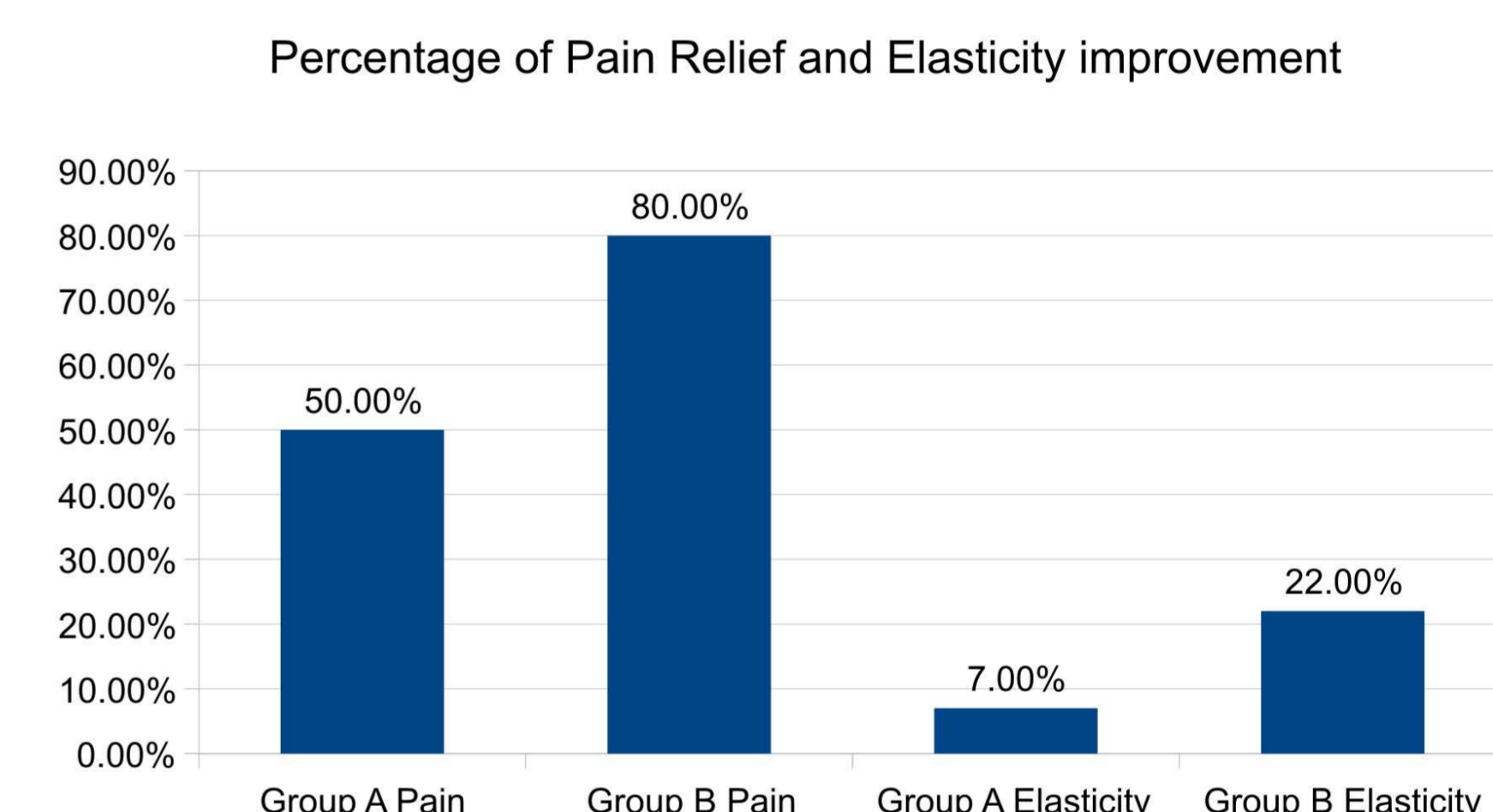

Fig. 3. Percentage of improvement in pain relief and elasticity improvement of Group A and Group B.

4. CONCLUSIONS

In this work, we have presented a portable RFD prototype implemented with commercial components. Characterization results of prototype shows output signals tuned in the range from 50 V to 120 V and an average current of 23 mA ranging from 500 KHz to 1 MHz. A comparative study on continuous mode and conventional of RFD treatments applied to patients with muscular diseases showed that the duration of exposure of RFD signal has a good impact in healing affected muscles. This investigation in the RFD field allows us to validate that the continuous application of an RFD signal in patients with a recent injury is an effective and fast-acting measure for reducing inflammation or healing muscle, ligament, and nerve injuries.

5. REFERENCES

- [1] C. L. Garrett, D. O. Draper, and K. L. Knight, "Heat distribution in the lower leg from pulsed short-wave diathermy and ultrasound treatments," *J. of Athletic Training*, vol. 35, no. 1, pp. 50-55, Jan. 2000..
- [2] C. Johnson, and A. Guy, "Non ionizing electromagnetic wave effects in biological materials and systems," in *Proc. of IEEE*, 1972, pp. 692-718.
- [3] L. Guo, N. J. Kubat, and R. A. Isenberg, "Pulsed radio frequency energy (PRFE) use in human medical applications," *J. of Electromagnetic Biology and Medicine*, vol. 30, no. 1, pp. 21-45, Jan. 2011.
- [4] R. W. Habash, R. Bansal, D. Krewski, and T. Hafid, "Thermal therapy, part 1: an introduction to thermal therapy," *J. Critical Reviews in Biomedical Engineering*, vol. 34, no. 6, pp. 459 – 489, Jan. 2006.
- [5] Equipos Cormat (2006). *Equipos de Fisioterapia* [Online]. Available: <http://www.cormat.mx/fisioterapia/radiofrecuencias>, Accessed on: Jan. 20, 2016.
- [6] Bourns Inc. (2010). *RLB9012-102KL RLB Series Radial Inductors*. [Online]. Available: <http://www.farnell.com/datasheets/1815097.pdf>, Accessed on: Jan. 20, 2016.
- [7] Steren de México (2016). *MOV-102 Bateria de Respaldo USB* [Online]. Available: <http://www.steren.com.mx/bateria-de-respaldo-power-bank-de-2000-mah.html>, Accessed on: Jan. 20, 2016.
- [8] M. Cameron, *Agentes Físicos en Rehabilitación*. Madrid, España: Elsevier España S.L., 2009.
- [9] J. Godges, "Dissertation abstracts international: The sciences and engineering," *J. Xerox University Microfilms*, vol. 30, no. 1, Jul. 1969.
- [10] R. Rivas and C. Santos, "Manejo del síndrome doloroso lumbar," *Int. J. Medicina General Integral Cubana*, vol. 26, pp. 117-128, May. 2010.